

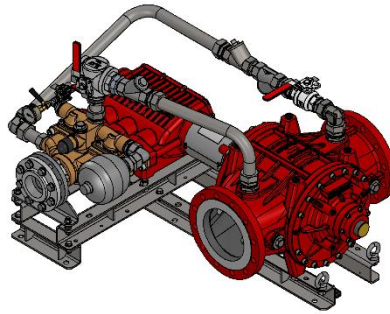



## ■ DATA SHEET PROPORTIONER FD8000 GEN III FOR STATIONARY EXTINGUISHING SYSTEMS.

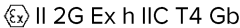

### ■ 1. TECHNICAL DATA.

Type	FD8000/0.5-S EV	FD8000/1-S EV	FD8000/3-S EV	FD8000/3/3-S EV
Proportioning rate	0.5 %	1 %	3 %	3% + 3% = 6%
Approvals <sup>1)</sup>	FM	–	 FM Approval PR463231	–
	DNV	 TAF00000GK		
Flow directions of water motor	Horizontal: "left → right" or "right → left"			
	Vertical: "top → bottom" or "bottom → top"			
Min. water flow rate <sup>2)</sup>	400 l/min	410 l/min	420 l/min	650 l/min
Min. water flow rate FM	–	880 l/min	520 l/min	–
Max. water flow rate	8000 l/min			
Operating temperature <sup>3)</sup>	5° C – 50° C (standard version)			
	5° C – 80° C (High-Temp version) <sup>x)</sup>			
Storage temperature	-20° C – 80° C			
Operating pressure	5 – 16 bar			
Weight <sup>4)</sup>				
Freshwater version	175 kg	228 kg	273 kg	360 kg
Seawater version <sup>x)</sup>	360 kg	413 kg	458 kg	545 kg
ATEX classification <sup>x)</sup> for +5 °C ≤ T <sub>a</sub> ≤ +60 °C	 II 2G Ex h IIC T4 Gb  II 2D Ex h IIIC T130 °C Gb			

1) Information regarding FM Approved data, please refer to [www.approvalguide.com](http://www.approvalguide.com). For DNV Approval conditions, see DNV Certificate TAF00000GK.

2) The nominal proportioning rate is achieved when reaching the specified minimum figure. Indication for proportioning of fluid Newtonian foam agents at operating pressure of 5 bar. For more detailed information, refer to page 2 and 3, item 3. "Minimum water flow rate".

3) Operating temp. is the max. ambient and medium (foam and extinguishing water) temperature. Max. foam agent temp. is generally limited to 50 °C.

4) Weight indications are based upon the standard version in dry condition. Special versions will differ.

X) Optional equipment.



1 / 6



[www.firedos.com](http://www.firedos.com)

## ■ 2. PRESSURE LOSS.

Indication valid for operating pressure of 10 bar. For more information on different system conditions or proportioning rates, please contact us.

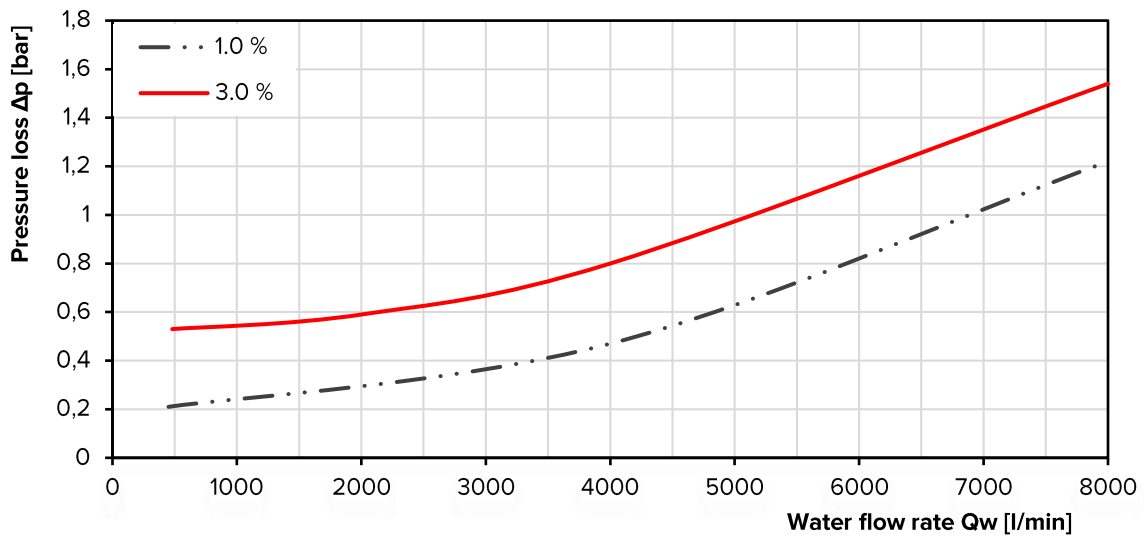

## ■ 3. MINIMUM WATER FLOW RATE.

The following diagrams show the effect of the operating pressure and foam agent viscosity on the minimum water flow rate (valid for viscosities in the graph at para. 4). The values can be reduced to approx. 35% by an optional flow reduction. The values increase by approx. 40% in the high-temp version. For values at other proportioning rates, please contact us.

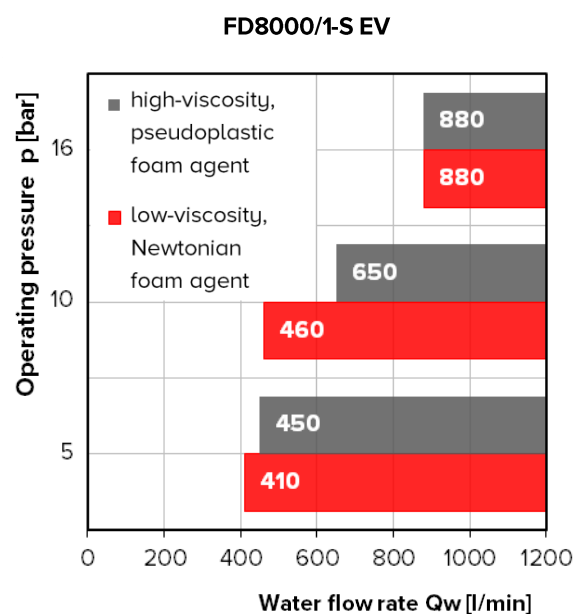
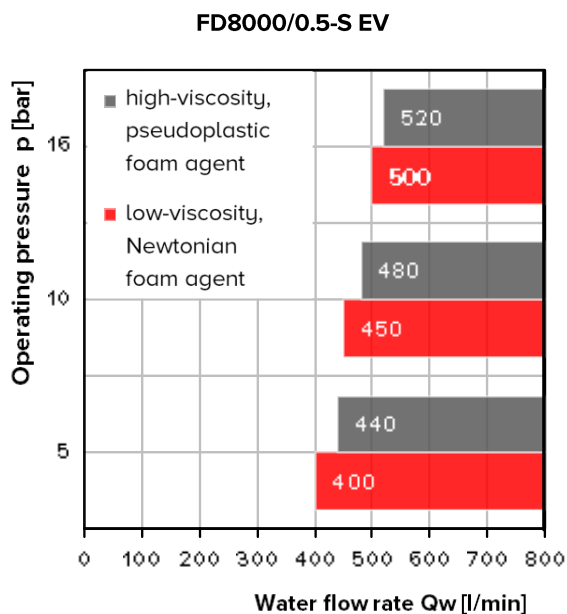

FD8000/3-S EV

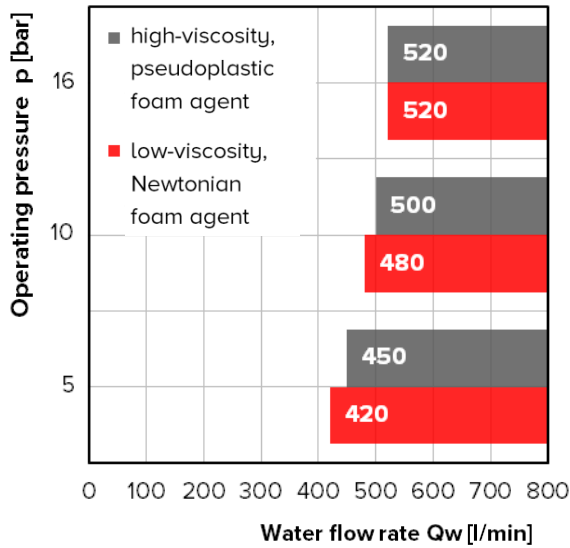

FD8000/3/3-S EV

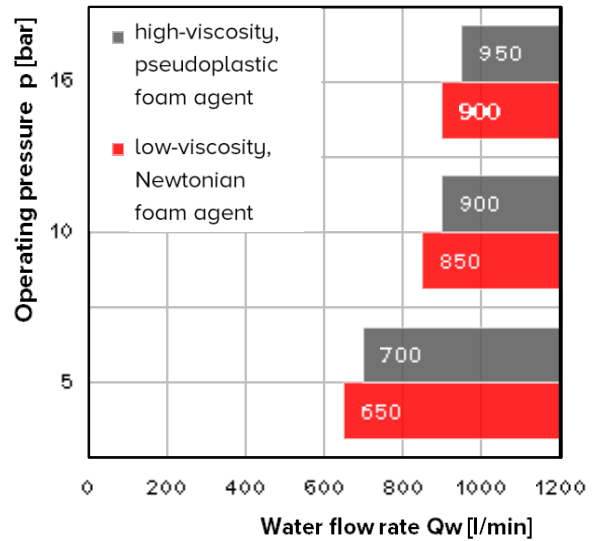

## 4. FOAM AGENT VISCOSITY.

*FireDos* proportioners are suitable for all foam agents available on the market. For reference regarding units with an FM Approval, please find the corresponding/associated range of dynamic viscosity below ([www.approvalguide.com](http://www.approvalguide.com)). Contact us if the dynamic viscosity of your foam agent is higher than the values in the diagram. **Do not hesitate to request our support for the correct dimensioning of your suction line.**

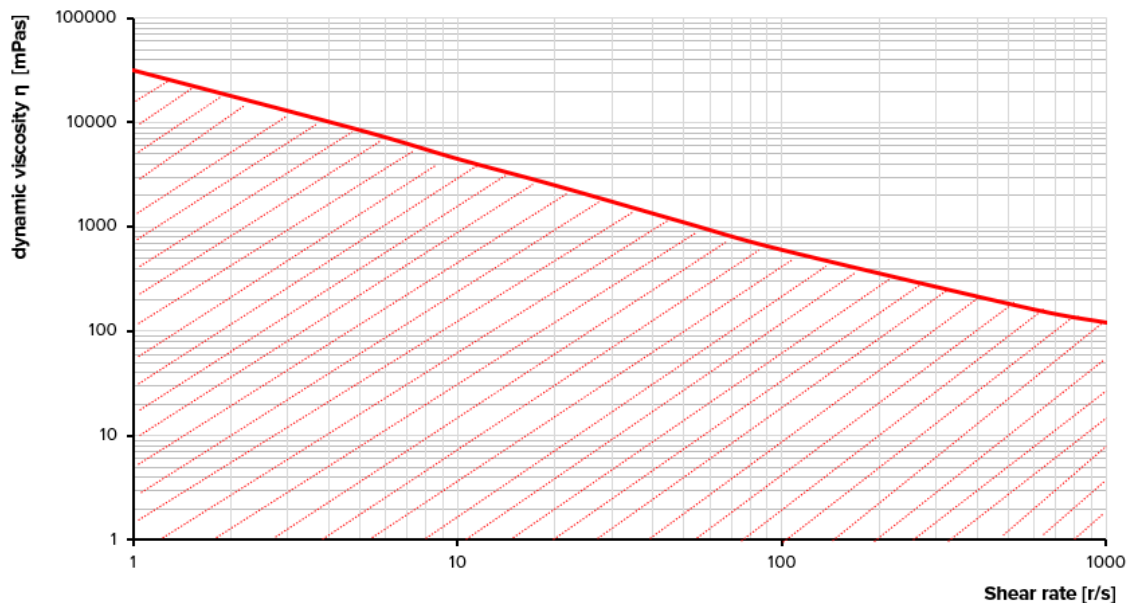

## 5. MATERIALS.

	Freshwater version	Seawater version
<b>Water motor</b> <sup>5)</sup>	Cast Aluminium G-AlSi7Mg HC-coated, AlMgSi1 HC-PTFE-coated, stainless steel 316 / 316Ti, POM, PVDF, NBR, FKM	Cast Bronze G-CuSn10, stainless steel 316 / 316Ti, Aluminium-Bronze CuAl10Fe5Ni5-C-GC, POM, PVDF, NBR, FKM
<b>Proportioning pump</b> <sup>5)</sup>	Stainless steel 316 / SS316Ti / 318 LN, POM, FKM, Aluminium oxide ceramic Al2O3, Aluminium-Bronze CuAl10Ni5Fe5-C-GC, PEEK	
<b>Pipework</b> <sup>5)</sup>	Stainless steel 316 / CF8M / SS316Ti, PTFE, FKM	
<b>Air bleed</b> <sup>5)</sup>	Stainless steel 316 / CF8M / SS316Ti, PTFE, brass	Stainless steel 316 / CF8M / SS316Ti, PTFE
<b>Support frame</b>	Stainless steel 304 / 316	

5) media-exposed materials

## 6. FLOW DIAGRAM.

Proportioning rate 0.5% / 1% / 3%

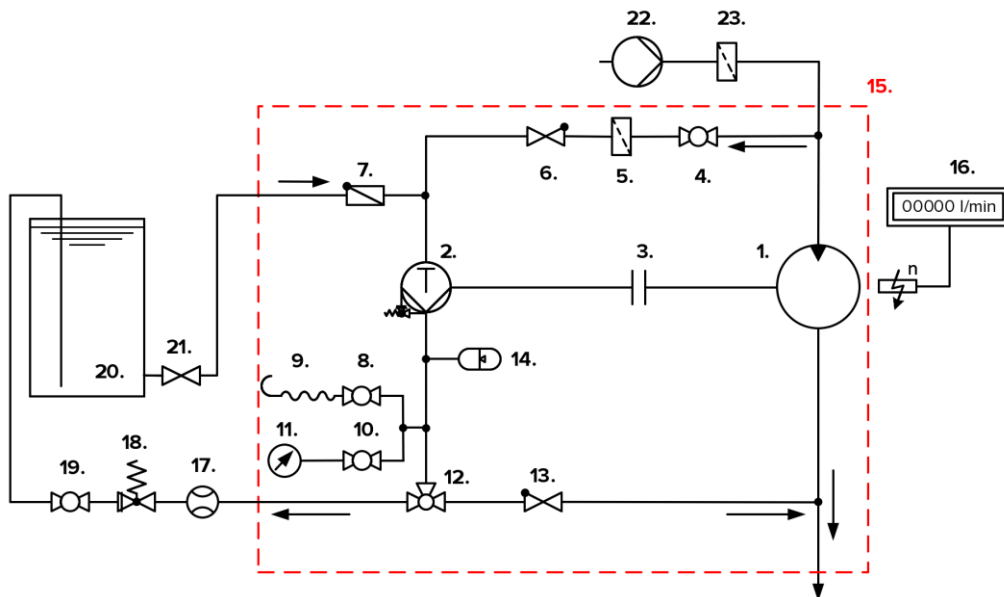

Proportioning rate 3% + 3% = 6%

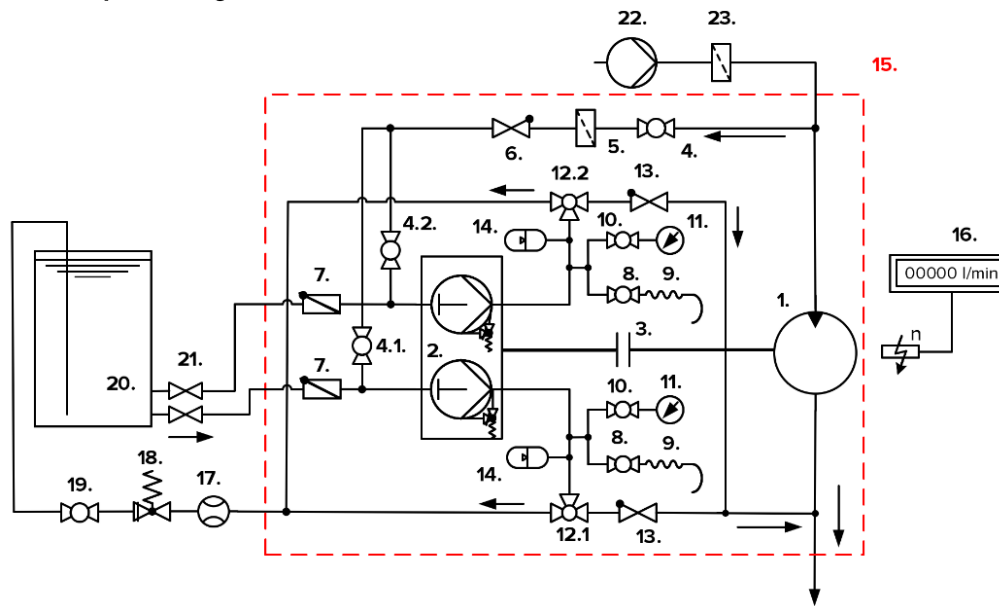

- |  |   |
|--|---|
| 1. Water motor                                   | 12.1 "Returning / Proportioning" pump head I                |
| 2. Proportioning pump                            | 12.2 "Returning / Proportioning" pump head II               |
| 3. Coupling                                      | 13. Check valve in the proportioning line                   |
| 4. 2-way ball valve "Flushing / Priming"         | 14. Pulsation damper <sup>y)</sup>                          |
| 4.1 "Flushing/Priming" pump head I               | 15. Standard scope of supply of <b>FireDos</b> proportioner |
| 4.2 "Flushing/Priming" pump head II              | 16. Revolution counter with flow rate display <sup>x)</sup> |
| 5. Filter in the flushing line                   | 17. Flow meter for return line <sup>x)</sup>                |
| 6. Check valve in the flushing line              | 18. Pressure sustaining valve for return line <sup>x)</sup> |
| 7. Non-return flap in the suction line           | 19. 2-way ball valve in return line <sup>x)</sup>           |
| 8. Air bleed valve                               | 20. Foam agent supply                                       |
| 9. Air bleed hose                                | 21. Shut-off valve in the suction line                      |
| 10. Shut-off valve pressure gauge                | 22. Extinguishing water supply                              |
| 11. Pressure gauge                               | 23. Water filter  |
| 12. 3-way ball-valve "Returning / Proportioning" |   |

<sup>x)</sup> Special version    <sup>y)</sup> not applicable for 0,5% proportioning rate

## 7. EXAMPLE FIGURE / DIMENSIONS.

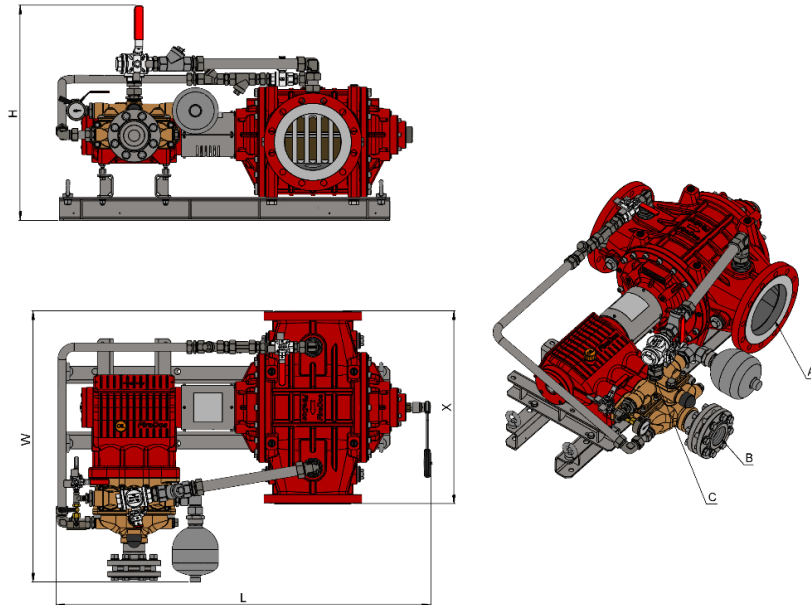

Type	FD8000/0.5-S EV	FD8000/1-S EV	FD8000/3-S EV	FD8000/3/3-S EV
Proportioning rate	0.5 %	1 %	3 %	3% + 3% = 6%
Connection water motor A	Optionally: - Flange acc. DIN EN 1092-1, DN200 PN16 RF (Standard) - Flange acc. ASME B16.5, 8" Class 150 RF			
Installation length water motor X <sup>6)</sup>	670 mm			
Connection suction line B	2" MT BSP or 2" MT NPT <sup>X)</sup>	2½" FT BSP or Flange acc. ASME B16.5, 2½" Class 150 RF <sup>X)</sup>	3" FT BSP or Flange acc. ASME B16.5, 3" Class 150 RF <sup>X)</sup>	2x 3" MT BSP or 2x Flange acc. ASME B16.5, 3" Class 150 RF <sup>X)</sup>
Connection return line C	1" FT BSP or 1" MT NPT <sup>X)</sup>	1¼" FT BSP or 1¼" MT NPT <sup>X)</sup>	2" FT BSP or 2" MT NPT <sup>X)</sup>	2x 2" FT BSP or 2x 2" MT NPT <sup>X)</sup>
Length L <sup>6)</sup>	1250 mm	1350 mm	1400 mm	1500 mm
Width W <sup>6)</sup>	710 mm	950 mm		1075 mm
Height H <sup>6)</sup>	680 mm	750 mm	820 mm	800 mm

All figures are approximate only and depend on the particular version / equipment options.

X) Special version.

6) Further accessories to the proportioner may require more installation space.

Please allow sufficient accessibility of the proportioner for maintenance work. For assistance to ensure sufficient accessibility, please refer to our planning manual for proportioners.

## 8. MANUFACTURER.

**FireDos** GmbH, Auf der Kaulbahn 6, 61200 Woelfersheim, Germany  
Phone +49 (0) 6036 9796-0, Email: info@firedos.de

We reserve the right to make modifications at any time.