

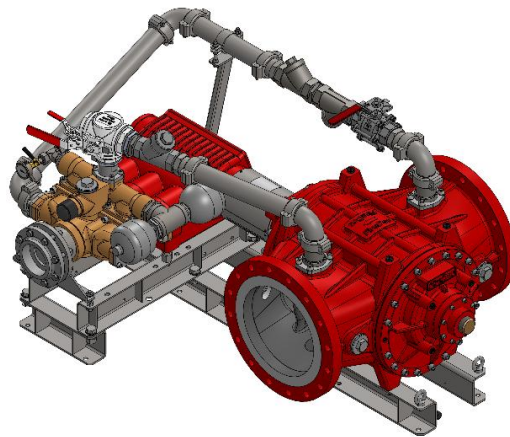



■ DATA SHEET PROPORTIONER FD25000 GEN III FOR STATIONARY EXTINGUISHING SYSTEMS.



■ 1. TECHNICAL DATA.

Type	FD25000/0.5-S EV	FD25000/1-S EV	FD25000/3-S EV	FD25000/3/3-S EV
Proportioning rate	0.5 %	1 %	3 %	3% + 3% = 6%
Approvals ¹⁾	 TAF00000GK			
Flow directions of water motor	Horizontal: "left → right" or "right → left"			
Min. water flow rate ²⁾	1200 l/min	1300 l/min	1800 l/min	2500 l/min
Max. water flow rate	25000 l/min			
Operating temperature ³⁾	5° C – 50° C (standard version)			
	5° C – 80° C (High-Temp version) ⁴⁾			
Storage temperature	-20° C – 80° C			
Operating pressure	5 – 16 bar			
Weight ⁴⁾				
Freshwater version	662 kg	705 kg	950 kg	1010 kg
Seawater version ^{x)}	1280 kg	1320 kg	1560 kg	1620 kg
ATEX classification ^{x)} for +5 °C ≤ T _a ≤ +60 °C	 II 2G Ex h IIC T4 Gb  II 2D Ex h IIIC T130 °C Db			

1) Information regarding DNV Approval conditions, see DNV Certificate TAF00000GK.

2) The nominal proportioning rate is achieved when reaching the specified minimum figure. Indication for proportioning of fluid Newtonian foam agents at operating pressure of 5 bar. For more detailed information, refer to page 2, item 3. "Minimum water flow rate".

3) Operating temp. is the max. ambient and medium (foam and extinguishing water) temperature. Max. foam agent temp. is generally limited to 50 °C.

4) Weight indications are based upon the standard version in dry condition. Special versions will differ.

X) Optional equipment.



■ 2. PRESSURE LOSS.

Indication valid for operating pressure of 10 bar. For more information on different system conditions or proportioning rates, please contact us.

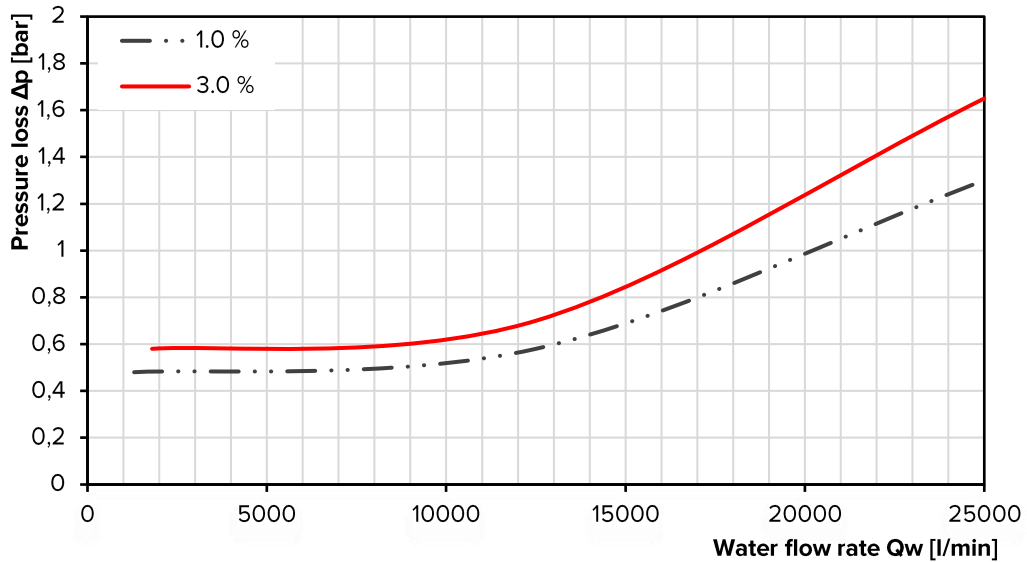

■ 3. MINIMUM WATER FLOW RATE.

The following diagrams show the effect of the operating pressure and foam agent viscosity on the minimum water flow rate (valid for viscosities in the graph at para. 4). The values can be reduced to approx. 35% by an optional flow reduction. The values increase by approx. 40% in the high-temp version. For values at other proportioning rates, please contact us.

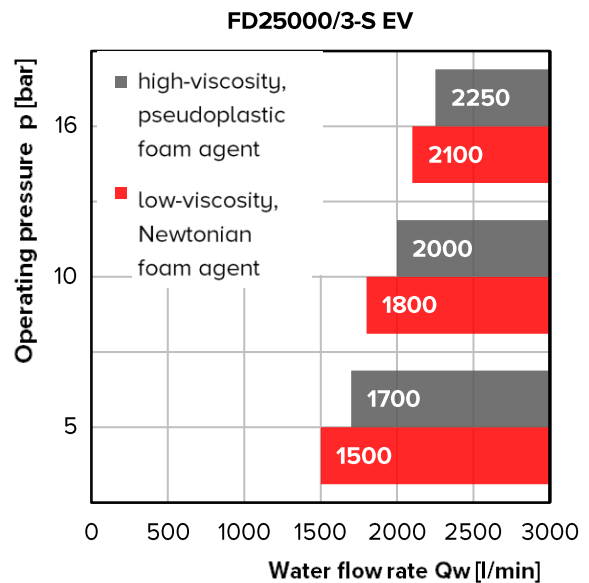
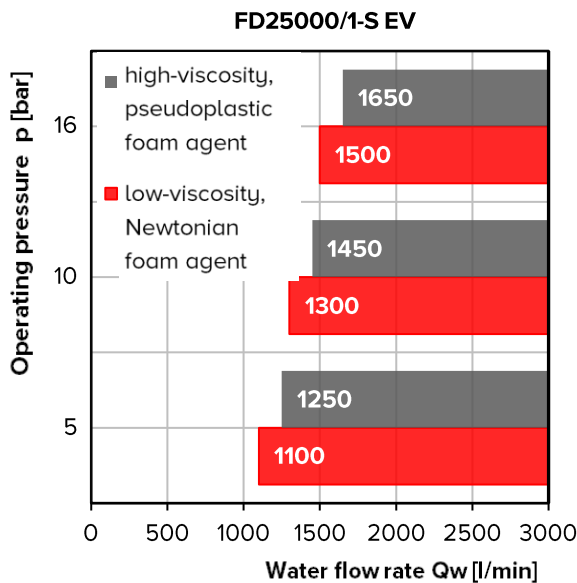

4. FOAM AGENT VISCOSITY.

FireDos proportioners are suitable for all foam agents available on the market. For reference, please find the corresponding/associated range of dynamic viscosity below. Contact us if the dynamic viscosity of your foam agent is higher than the values in the diagram. **Do not hesitate to request our support for the correct dimensioning of your suction line.**

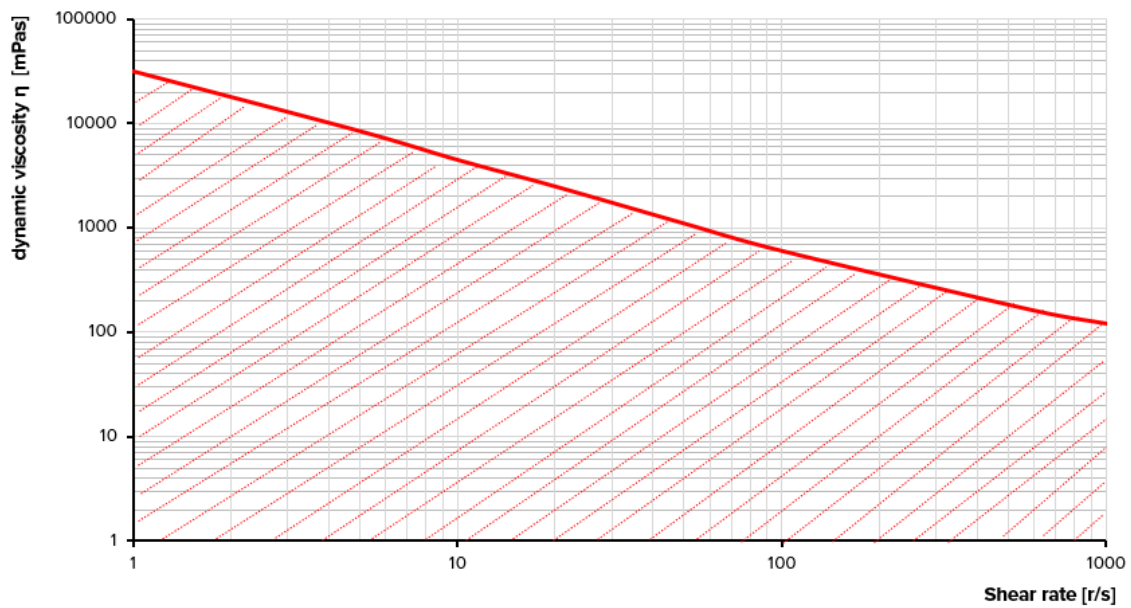

5. MATERIALS.

	Freshwater version	Seawater version
Water motor ⁵⁾	Cast Aluminium G-AlSi7Mg HC-coated, Aluminium-Bronze CuAl10Fe5Ni5-C-GC, stainless steel 316 / 316Ti, POM, PVDF, NBR, FKM	Cast Bronze G-CuSn10, stainless steel 316 / 316Ti, Aluminium-Bronze CuAl10Fe5Ni5-C-GC, POM, PVDF, NBR, FKM
Proportioning pump ⁵⁾	Stainless steel 316 / SS316Ti / 318 LN, POM, FKM, Aluminium oxide ceramic Al ₂ O ₃ , Aluminium-Bronze CuAl10Ni5Fe5-C-GC, PEEK	
Pipework ⁵⁾	Stainless steel 316 / CF8M / SS316Ti, PTFE, FKM	
Air bleed ⁵⁾	Stainless steel 316 / CF8M / SS316Ti, PTFE, brass	Stainless steel 316 / CF8M / SS316Ti, PTFE
Support frame	Stainless steel 304 / 316	

⁵⁾ media-exposed materials

6. FLOW DIAGRAM.

Proportioning rate 0.5% / 1% / 3%

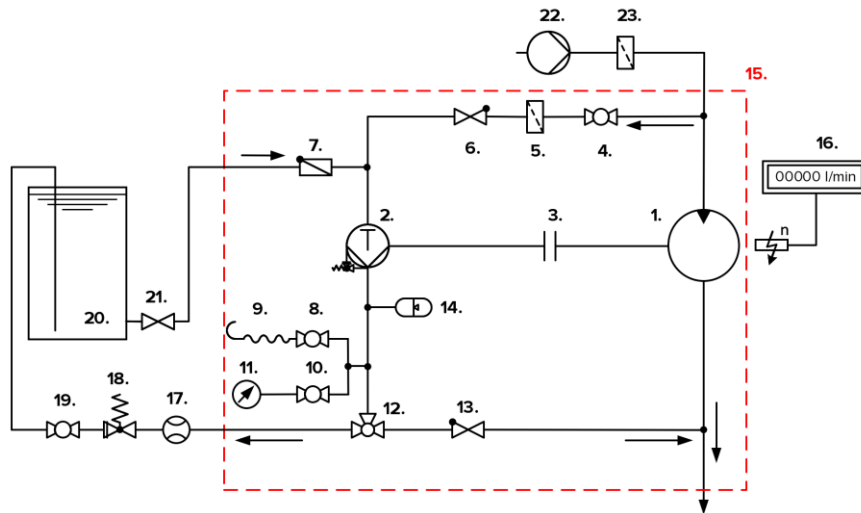

Proportioning rate 3% + 3% = 6%

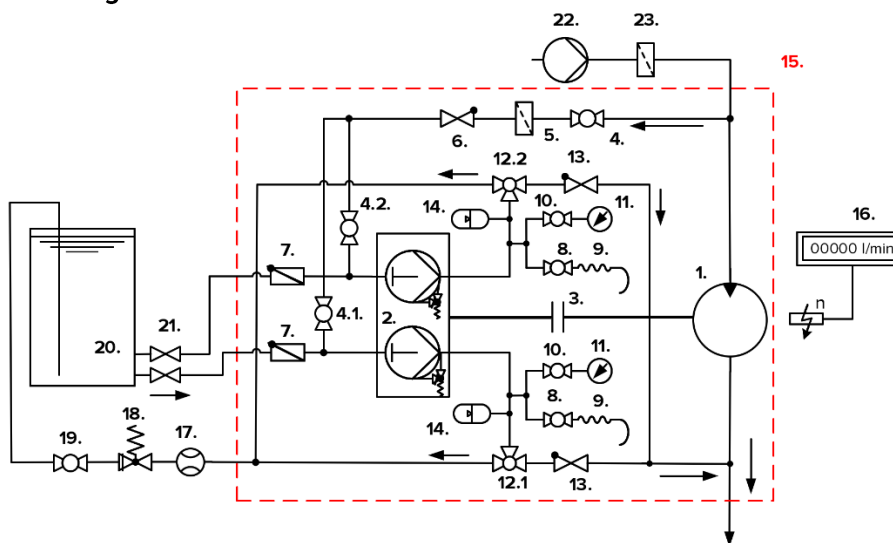

- | | |
|------------------------------------------------|-------------------------------------------------------------|
| 1. Water motor | 12.1 "Returning/Proportioning" pump head I |
| 2. Proportioning pump | 12.2 "Returning/Proportioning" pump head II |
| 3. Coupling | 13. Check valve in the proportioning line |
| 4. 2-way ball valve "Flushing/Priming" | 14. Pulsation damper |
| 4.1 "Flushing/Priming" pump head I | 15. Standard scope of supply of FireDos proportioner |
| 4.2 "Flushing/Priming" pump head II | 16. Revolution counter with flow rate display ^{x)} |
| 5. Filter in the flushing line | 17. Flow meter for return line ^{x)} |
| 6. Check valve in the flushing line | 18. Pressure sustaining valve for return ^{x)} |
| 7. Non-return flap in the suction line | 19. 2-way ball valve in return line ^{x)} |
| 8. Air bleed valve | 20. Foam agent supply |
| 9. Air bleed hose | 21. Shut-off valve in the suction line |
| 10. Shut-off valve pressure gauge | 22. Extinguishing water supply |
| 11. Pressure gauge | 23. Water filter |
| 12. 3-way ball valve "Returning/Proportioning" | |

X) Special version

7. EXAMPLE FIGURE / DIMENSIONS.

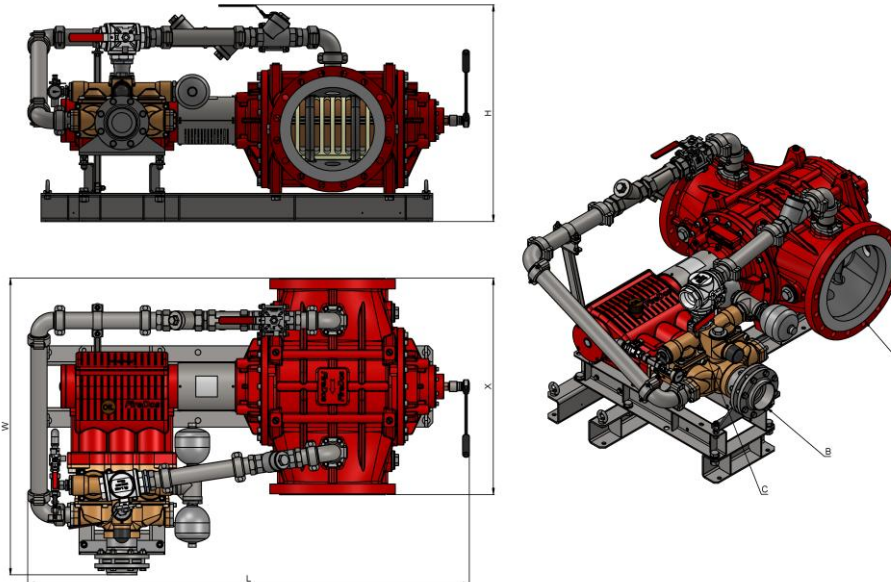

Type	FD25000/0.5-S EV	FD25000/1-S EV	FD25000/3-S EV	FD25000/3/3-S EV
Proportioning rate	0.5 %	1 %	3 %	3% + 3% = 6%
Connection water motor A	Optionally: - Flange acc. DIN EN 1092-1, DN400 PN16 RF (Standard) - Flange acc. ASME B16.5, 16" Class 150 RF			
Installation length water motor X ⁶⁾	1000 mm			
Connection suction line B	2½" MT BSP or Flange acc. ASME B16.5 2½" Class 150 ^{X)}	3" FT BSP or Flange acc. ASME B16.5 3" Class 150 ^{X)}	5" FT BSP or Flange acc. ASME B16.5 6" Class 150 ^{X)}	2x 5" FT BSP or 2x Flange acc. ASME B16.5 6" Class 150 ^{X)}
Connection return line C	1½" FT BSP or 1½" MT NPT ^{X)}	2" FT BSP or 2" MT NPT ^{X)}	3" FT BSP or Victaulic OGS DN65 ^{X)}	2x 3" FT BSP or 2x Victaulic OGS DN65 ^{X)}
Length L ⁶⁾	1805 mm	1850 mm	2040 mm	2150 mm
Width W ⁶⁾	1020 mm	1110 mm	1360 mm	1720 mm
Height H ⁶⁾	840 mm	870 mm	1002 mm	1115 mm

All figures are approximate only and depend on the particular version / equipment options.

X) Special version.

6) Further accessories to the proportioner may require more installation space.

Please allow sufficient accessibility of the proportioner for maintenance work. For assistance to ensure sufficient accessibility, please refer to our planning manual for proportioners.

8. MANUFACTURER.

FireDos GmbH, Auf der Kaulbahn 6, 61200 Woelfersheim, Germany

Phone +49 (0) 6036 9796-0, Email: info@firedos.de

We reserve the right to make modifications at any time.